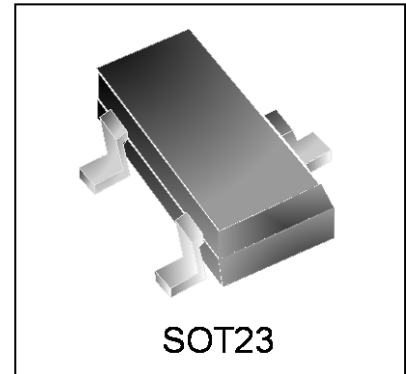

**Features**

- 400 watts peak pulse power ( $t_p = 8/20\mu s$ )
- Protects two  $-7V$  to  $12V$  lines
- Low capacitance
- Low clamping voltage
- Solid-state silicon avalanche technology

**IEC COMPATIBILITY (EN61000-4)**

- IEC 61000-4-2 (ESD)  $\pm 15kV$  (air),  $\pm 8kV$  (contact)
- IEC 61000-4-4 (EFT) 40A (5/50ns)
- IEC 61000-4-5 (Lightning) 12A (8/20 $\mu s$ )

**Mechanical Characteristics**

- JEDEC SOT23 package
- Molding compound flammability rating: UL 94V-0
- Marking : Making Code
- Packaging : Tape and Reel per EIA 481

**Applications**

- Protection of RS-485 transceivers with extended common-mode range
- Security systems
- Automatic Teller Machines
- HFC systems
- Net works

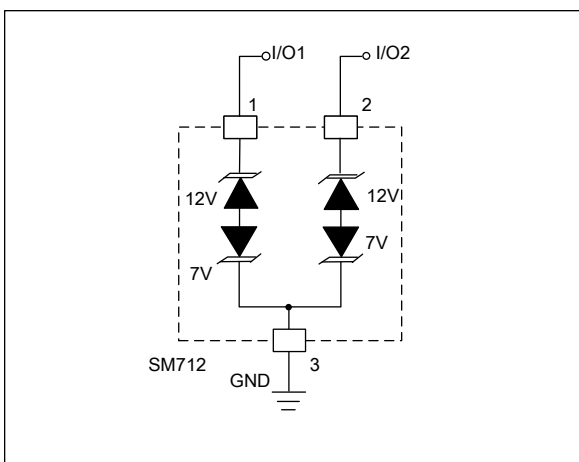
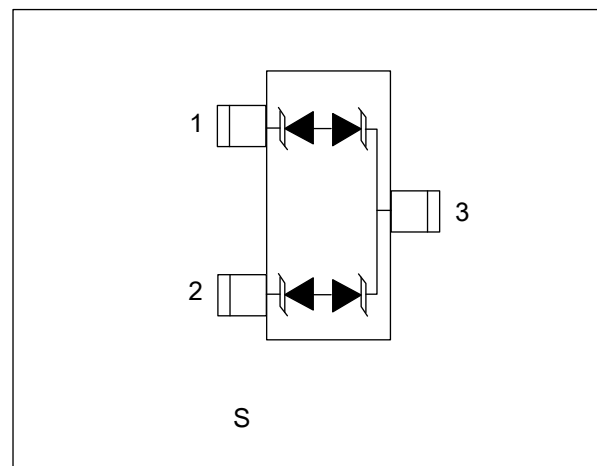
**Circuit Diagram****Schematic & PIN Configuration**

Absolute Maximum Rating			
Rating	Symbol	Value	Units
Peak Pulse Power ( $t_p = 8/20\mu s$ )	$P_{PP}$	400	Watts
Lead Soldering Temperature	$T_L$	260(10 sec.)	°C
Peak Pulse Current ( $t_p = 8/20\mu s$ )	$I_{pp}$	17	A
Operating Temperature	$T_J$	-55 to + 125	°C
Storage Temperature	$T_{STG}$	-55 to +150	°C

### Electrical Parameters (T=25°C)

Symbol	Parameter
$I_{PP}$	Maximum Reverse Peak Pulse Current
$V_C$	Clamping Voltage @ $I_{PP}$
$V_{RWM}$	Working Peak Reverse Voltage
$I_R$	Maximum Reverse Leakage Current @
$V_{BR}$	Breakdown Voltage @ $I_T$
$I_T$	Test Current
$I_F$	Forward Current
$V_F$	Forward Voltage @ $I_F$

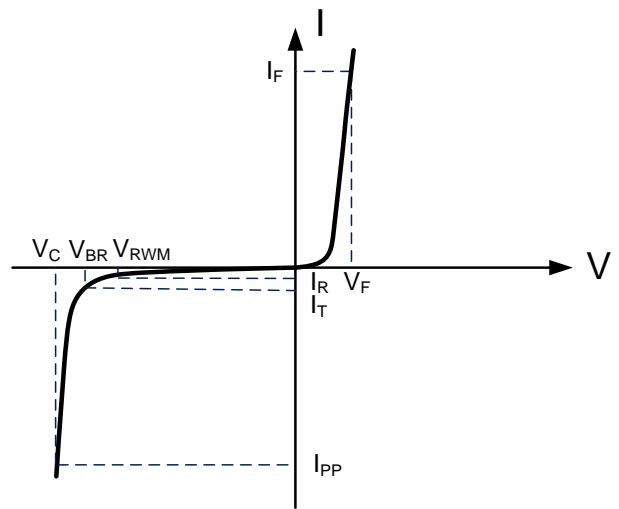

### Electrical Characteristics

SM712M									
Parameter	Symbol	Conditions	Pins 1 to 3 and 2 to 3 (12V TVS)			Pins 3 to 1 and 3 to 2 (7V TVS)			Units
			Min	Typ	Max	Min	Typ	Max	
Reverse Stand-Off Voltage	$V_{RWM}$	Pin 3 to 1 or Pin 2 to 1			12			7	V
Reverse Breakdown Voltage	$V_{BR}$	$I_{PT} = 1mA$	13.3			7.5			V
Reverse Leakage Current	$I_R$	$V_R = V_{RWM}$			1			20	$\mu A$
Clamping Voltage	$V_C$	$I_{PP} = 5A$ , $t_p = 8/20\mu s$			20			10	V
Clamping Voltage	$V_C$	$I_{PP} = 17A$ , $t_p = 8/20\mu s$			26			12	V
Junction Capacitance	$C_j$	$V_R = 0V$ , $f = 1MHz$			75			75	pF
		$V_R = V_{RWM}$ , $f = 1MHz$		45			45		pF

## Typical Characteristics

Figure 1 Non-Repetitive Peak Pulse Power vs. Pulse Time

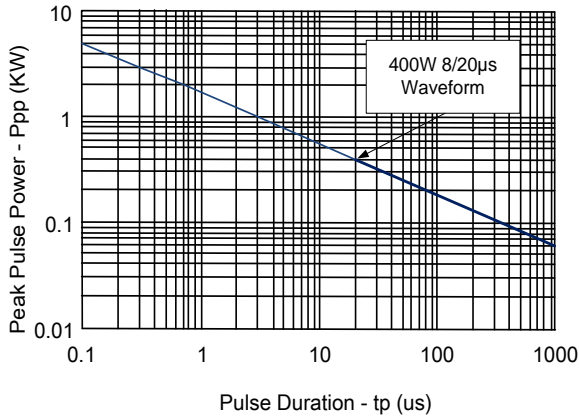

Figure 2 Power Derating curve

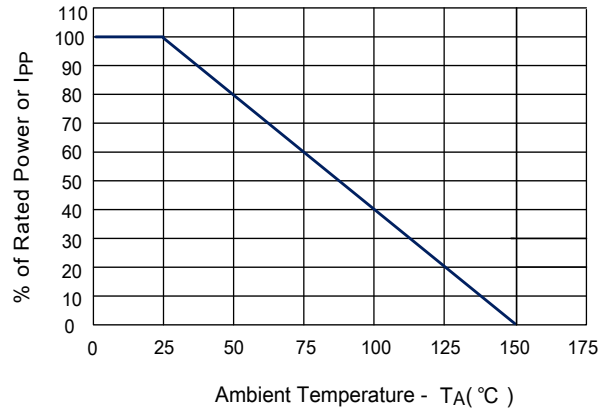

Figure 3 Pulse Waveform

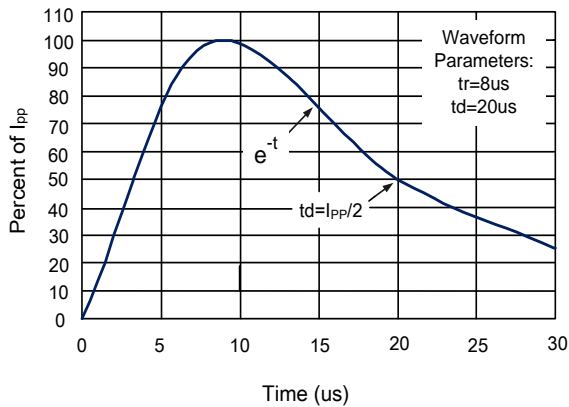

Figure 4 Clamping Voltage vs. Peak Pulse Current

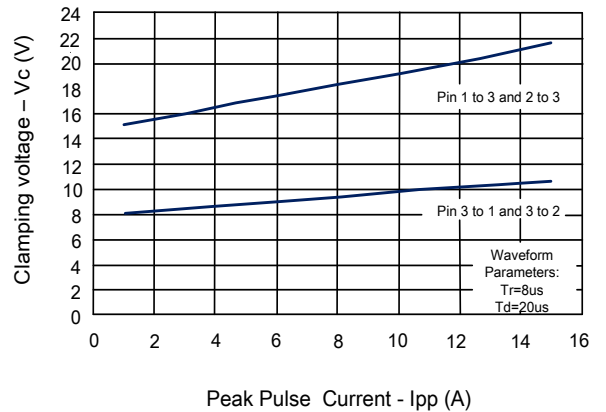
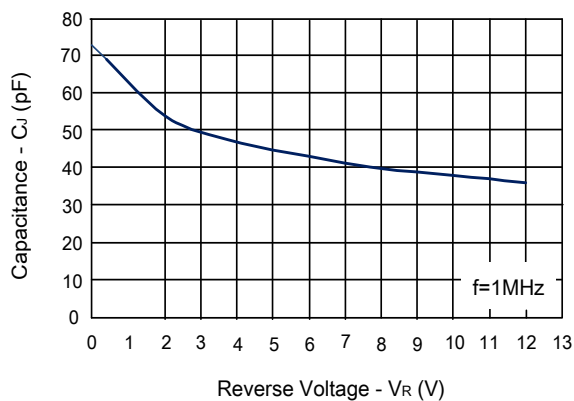

Figure 5 Capacitance vs. Reverse Voltage



## Application Information

### Device Connection for Protection of Two RS-485 Data Lines

EIA RS-485 specifies a  $\pm 7V$  ground difference between devices on the bus. This permits the bus voltage to range from +12V (5V + 7V) to -7V (0 - 7V).

The SM712M is designed to protect two RS-485 data lines in extended common mode applications. The SM712M may be used to protect devices from transient voltages resulting from ESD, EFT, and lightning. The device is designed with asymmetrical operating voltages for optimum protection. The TVS diodes at pins 1 and 2 have a working voltage of 12 volts. These pins are connected to the differential data line pairs. The TVS diodes at pin 3 have a working voltage of 7 volts. Pin 3 is connected to ground. The internal TVS diodes of the WS712M will protect the transceiver input from positive transient voltage spikes greater than 12V and Negative spikes greater than 7V.

A series current limiting resistor may be added in applications requiring enhanced surge immunity.

### RS-485 Common Mode Voltages

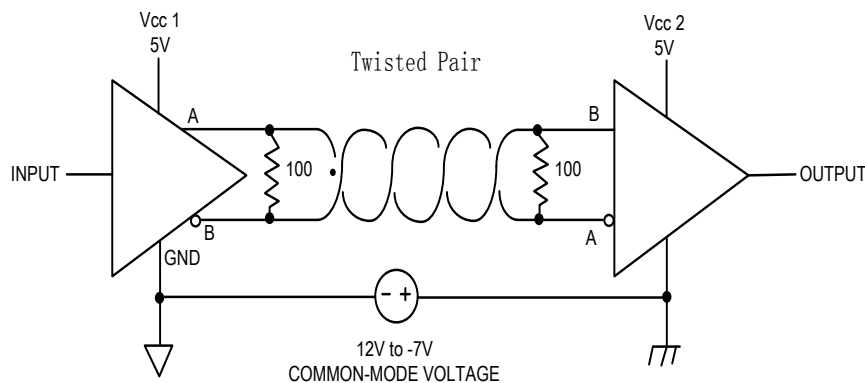

### RS-485 Protection Circuit

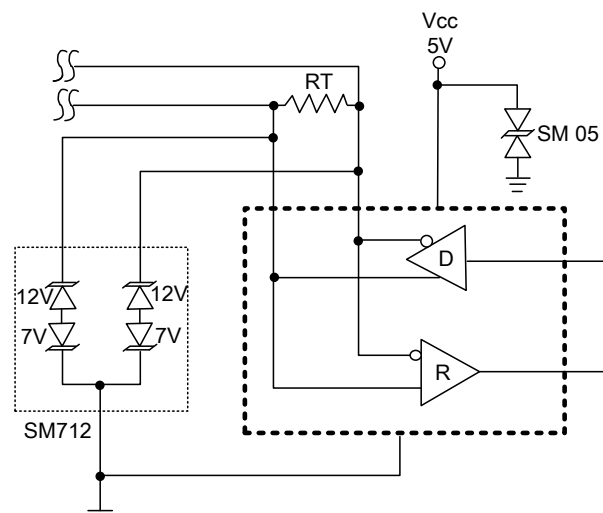

## Outline Drawing – SOT23

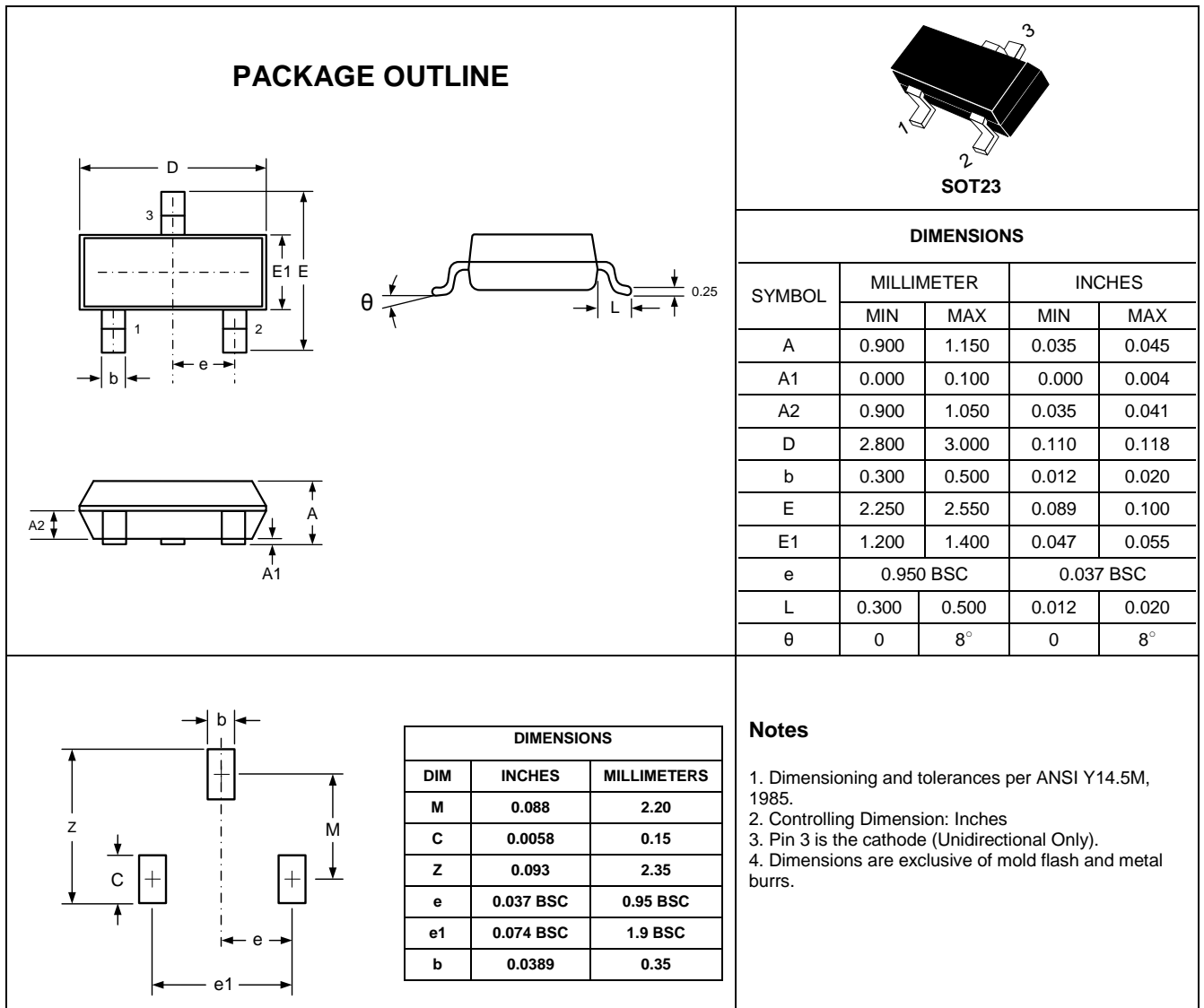

## Marking Codes

Part Number	SM712M
Marking Code	7AM